

Name of Faculty: NAVEEN ASATI

Designation: ASSO. PROF.

Department: ELECTRICAL & ELECTRONICS ENGINEERING

Subject: BASIC ELECTRICAL & ELECTRONICS ENGINEERING

Subject Code: BT-104

Unit: 4

Topic: INDUCTION MOTOR

## INDUCTION MOTOR

- ✓ An induction motor (also known as an asynchronous motor) is a commonly used AC electric motor.
- ✓ In an induction motor, the electric current in the rotor needed to produce torque is obtained via electromagnetic induction from the rotating magnetic field of the stator winding.
- ✓ The rotor of an induction motor can be a squirrel cage rotor or wound type rotor.
- ✓ Induction motors are referred to as 'asynchronous motors' because they operate at a speed less than their synchronous speed.

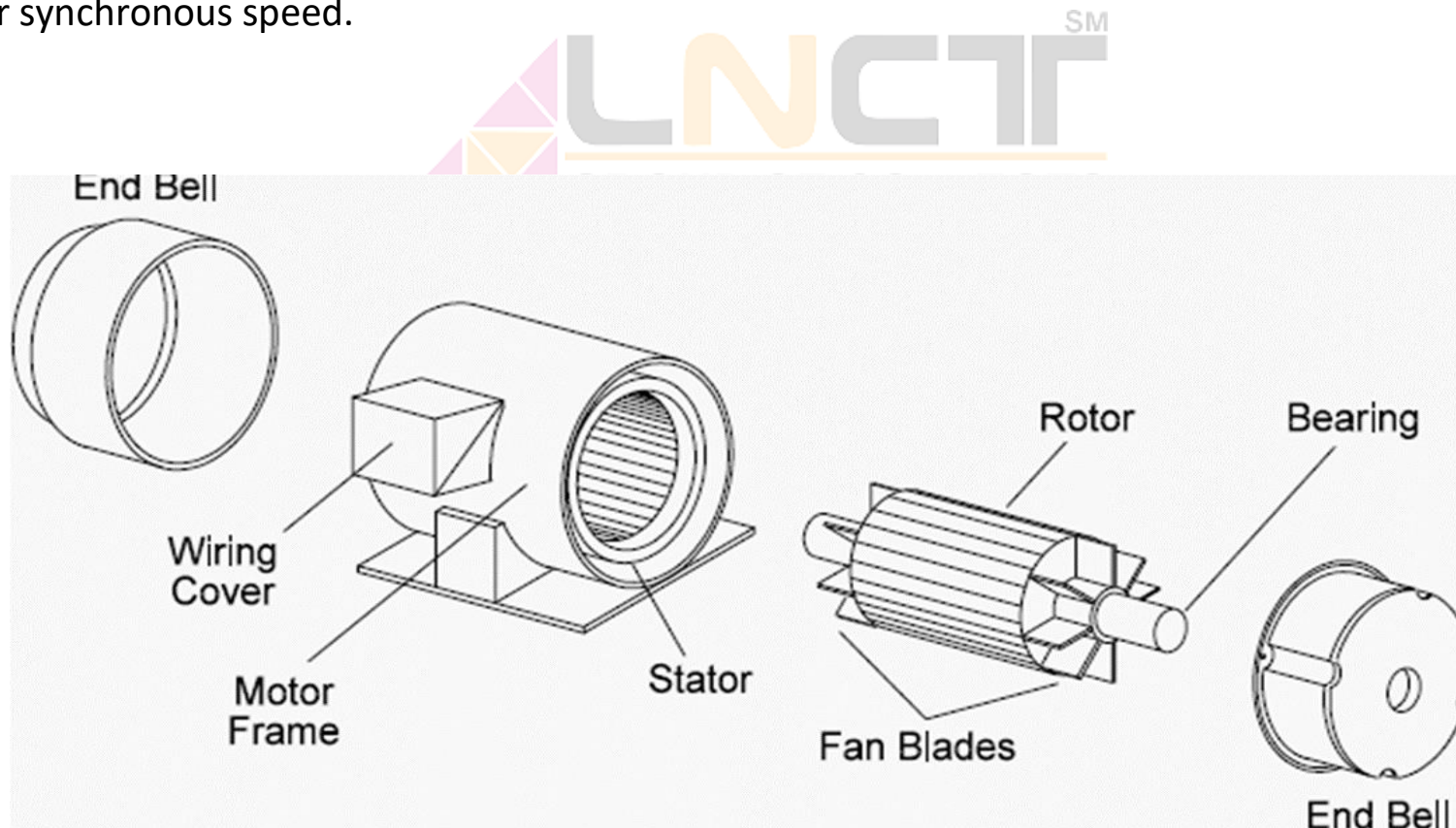

## Synchronous Speed

- ✓ Synchronous speed is the speed of rotation of the magnetic field in a rotary machine and it depends upon the frequency and number poles of the machine.
- ✓ An induction motor always runs at a speed less than synchronous speed because the rotating magnetic field which is produced in the stator will generate flux in the rotor which will make the rotor to rotate, but due to the lagging of flux current in the rotor with flux current in the stator, the rotor will never reach to its rotating magnetic field speed. i.e. the synchronous speed.
- ✓ An AC motor's synchronous speed, is the rotation rate of the stator's magnetic field, which is expressed in revolutions per minute as

$$N_s = \frac{120 \times f}{P} \text{ RPM}$$

Where  $f$  is the motor supply's frequency in hertz and  $p$  is the number of magnetic poles. i.e., for a six-pole three-phase motor with three pole-pairs set  $120^\circ$  apart,  $p$  equals 6 and  $n_s$  equals 1,000 RPM and 1,200 RPM respectively for 50 Hz and 60 Hz supply systems.

## Rotating Magnetic Field

When a 3-phase winding is energized from a 3-phase supply, a rotating magnetic field is produced.

This field is such that its poles do not remain in a fixed position on the stator but go on shifting their positions around the stator.

For this reason, it is called a rotating field.

The magnitude of this rotating field is constant and is equal to  $1.5 \Phi_m$ .

where  $\Phi_m$  is the maximum flux due to any phase.

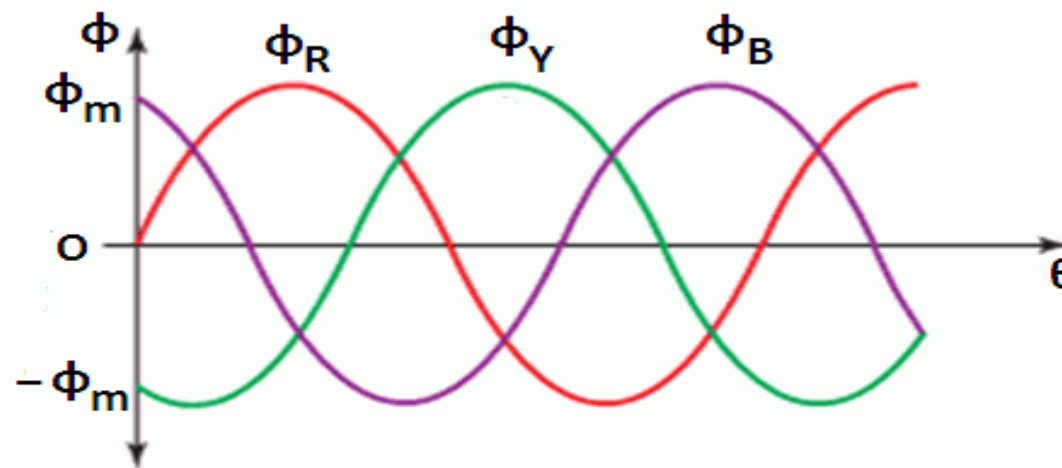

Fluxes produced by line currents

## Working Principle of Induction Motor

The motor which works on the principle of electromagnetic induction is known as the induction motor. The electromagnetic induction is the phenomenon in which the electromotive force induces across the electrical conductor when it is placed in a rotating magnetic field.

When the three phase supply is given to the stator, the rotating magnetic field produced on it. The figure below shows the rotating magnetic field set up in the stator.

The polarities of the magnetic field vary by concerning the positive and negative half cycle of the supply. The change in polarities makes the magnetic field rotates.

The conductors of the rotor are stationary. This stationary conductor cut the rotating magnetic field of the stator, and because of the electromagnetic induction, the EMF induces in the rotor. This EMF is known as the rotor induced EMF, and it is because of the electromagnetic induction phenomenon.

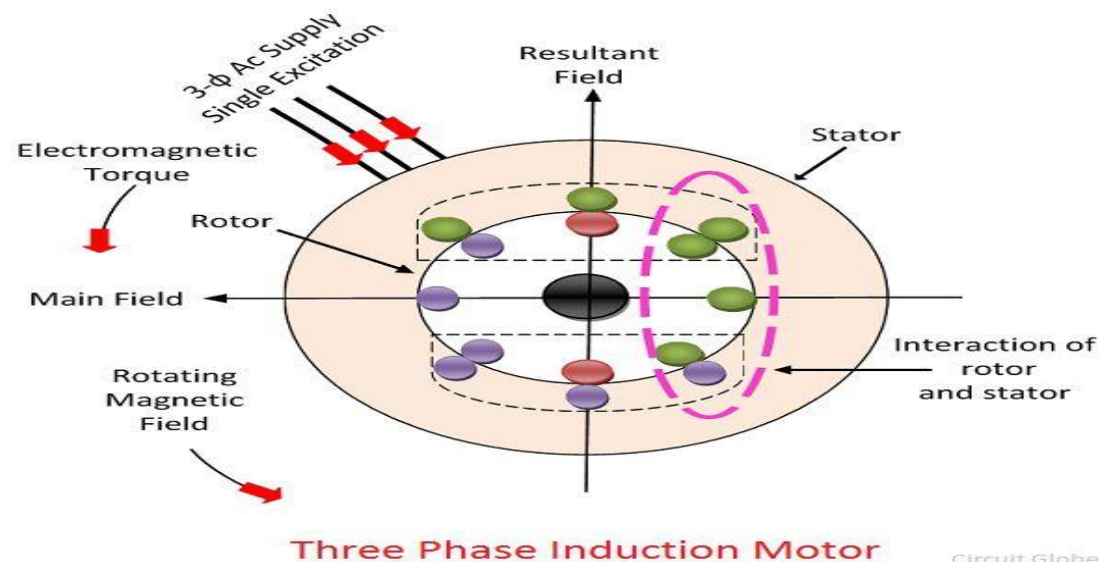

# LNCT GROUP OF COLLEGES

The conductors of the rotor are short-circuited either by the end rings or by the help of the external resistance. The relative motion between the rotating magnetic field and the rotor conductor induces the current in the rotor conductors. As the current flows through the conductor, the flux induces on it. The direction of rotor flux is same as that of the rotor current.

Now we have two fluxes one because of the rotor and another because of the stator. These fluxes interact each other. On one end of the conductor the fluxes cancel each other, and on the other end, the density of the flux is very high. Thus, the high-density flux tries to push the conductor of rotor towards the low-density flux region. This phenomenon induces the torque on the conductor, and this torque is known as the electromagnetic torque.

The direction of electromagnetic torque and rotating magnetic field is same. Thus, the rotor starts rotating in the same direction as that of the rotating magnetic field.

The speed of the rotor is always less than the rotating magnetic field or synchronous speed. The rotor tries to run at the speed of the rotor, but it always slips away. Thus, the motor never runs at the speed of the rotating magnetic field, and this is the reason because of which the induction motor is also known as the asynchronous motor.

## Slip

Induction motor rotor always rotate at a speed less than synchronous speed. The difference between the main flux speed ( $N_s$ ) and their rotor speed ( $N$ ) is called slip.

## LNCT GROUP OF COLLEGES

It is usually expressed as a percentage of synchronous speed ( $N_s$ ) and is represented by  $s$ .

$$\% \text{ slip } s = \frac{N_s - N}{N_s} \times 100 \quad \text{or} \quad \text{fractional slip, } s = \frac{N_s - N}{N_s}$$

Therefore rotor speed  $N = N_s (1 - s)$

The difference between synchronous speed and rotor speed is called slip speed i.e.,

$$\text{Slip speed} = N_s - N$$

### Frequency of Rotor Current or EMF

The frequency of both the rotor emf and rotor current depends upon the rate of cutting flux by the rotor conductors i.e. on the relative speed between the stator revolving magnetic field and rotor and is given by the expression.

$$\text{Frequency of rotor current, } f' = sf$$

Where  $s$  is the slip and  $f$  is the supply frequency.

# LNCT GROUP OF COLLEGES

## Construction of Induction Motor

A three phase Induction motor mainly consists of two parts called as the **Stator** and the **Rotor**. The stator is the stationary part of the induction motor, and the rotor is the rotating part. The construction of the stator is similar to the three-phase synchronous motor, and the construction of rotor is different for the different machine.

### Construction of Stator

The stator is built up of high-grade alloy steel laminations to reduce eddy current losses. It has three main parts, namely **outer frame**, the **stator core** and a **stator winding**.

#### Outer frame

It is the outer body of the motor. Its main function is to support the stator core and to protect the inner parts of the machine. For small machines, the outer frame is casted, but for the large machine, it is fabricated. The figure below shows the stator construction.

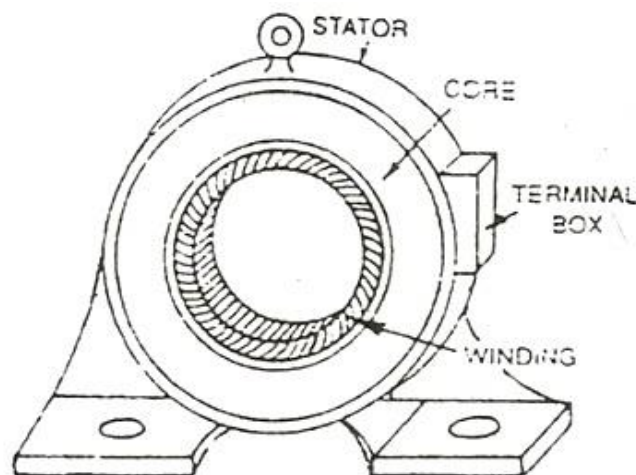



# LNCT GROUP OF COLLEGES

## Stator Core

The stator core is built of high-grade silicon steel stampings. Its main function is to carry the alternating magnetic field which produces hysteresis and eddy current losses. The stampings are fixed to the stator frame. Each stamping are insulated from the other with a thin varnish layer. The thickness of the stamping usually varies from 0.3 to 0.5 mm. Slots are punched on the inner side of the stampings to accommodate stator winding.

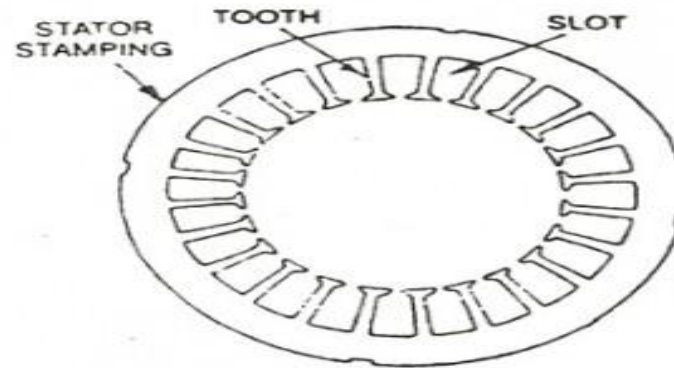

## Stator windings

The core of the stator carries three phase windings which are usually supplied from a three-phase supply system. The six terminals of the windings (two of each phase) are connected in the terminal box of the machine. The stator of the motor is wound for a definite number of poles, depending on the speed of the motor. If the number of poles is greater, the speed of the motor will be less and if the number of poles is less than the speed will be high.

As the relationship between the speed and the pole of the motor is given as

$$N_s \propto \frac{1}{p} \quad \text{or} \quad N_s = \frac{120f}{p}$$

# LNCT GROUP OF COLLEGES

## Construction of Rotor

The rotor is also built of thin laminations of the same material as the stator. The laminated cylindrical core is mounted directly on the shaft. These laminations are slotted on the outer side to receive the conductors. There are two types of rotor.

- (i) Squirrel Cage Rotor
- (ii) Phase Wound Rotor

## Squirrel Cage Rotor

A squirrel cage rotor consists of a laminated cylindrical core. The circular slots at the outer periphery are semi-closed. Each slot contains uninsulated bar conductor of aluminium or copper. At the end of the rotor the conductors are short-circuited by a heavy ring of copper or aluminium. The rotor slots are usually not parallel to the shaft but are skewed.

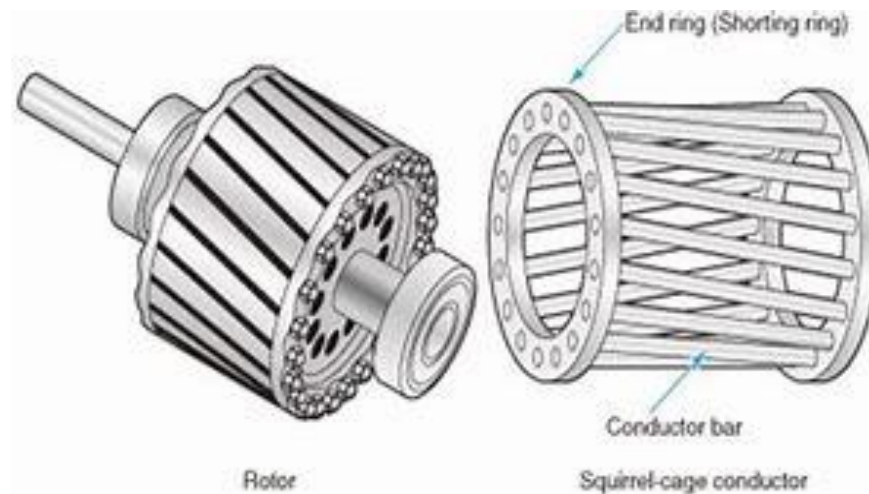

# LNCT GROUP OF COLLEGES

The skewing of the rotor conductors has the following advantages given below.

- ✓ It reduces humming and provide smooth and noise free operation.
- ✓ It results in a uniform torque curve for different positions of the rotor.
- ✓ The locking tendency of the rotor is reduced, as the teeth of the rotor and the stator attract each other and lock.
- ✓ It increases the rotor resistance due to the increased length of the rotor bar conductors.

## Phase Wound Rotor

The Phase wound rotor is also called as Slip Ring Rotor. It consists of a cylindrical core which is laminated. The outer periphery of the rotor has a semi-closed slot which carries a 3 phase insulated windings. The rotor windings are connected in star. The slip rings are mounted on the shaft with brushes resting on them. The brushes are connected to the variable resistor. The function of the slip rings and the brushes is to provide a means of connecting external resistors in the rotor circuit.

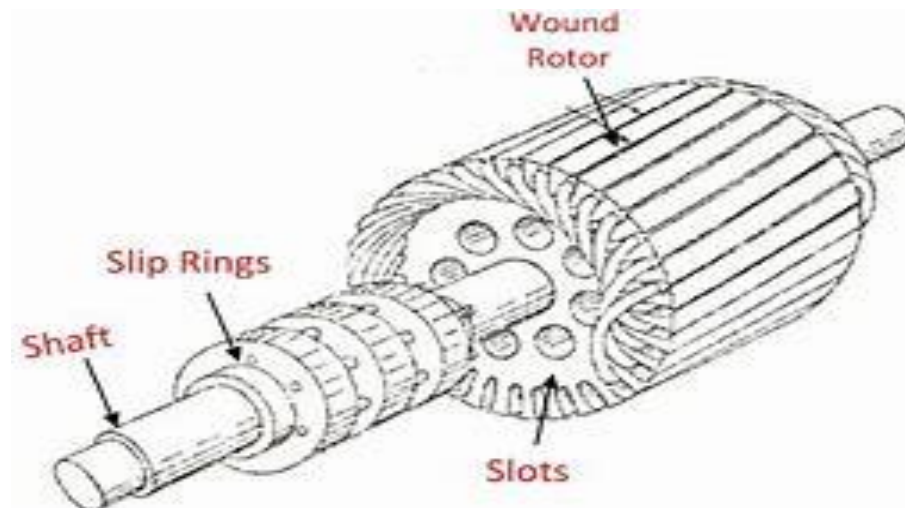

# LNCT GROUP OF COLLEGES

The resistor enables the variation of each rotor phase resistance to serve the following purposes given below:

- ✓ It increases the starting torque and decreases the starting current.
- ✓ It is used to control the speed of the motor.

In this type also, the rotor is skewed. A mild steel shaft is passed through the center of the rotor and is fixed to it. The purpose of the shaft is to transfer mechanical power.

## Comparison of Phase wound and Squirrel cage rotor IM

S.N.	Phase Wound or Slip Ring IM	Squirrel Cage IM
1	Construction is complicated due to presence of slip ring and brushes	Construction is very simple
2	The rotor winding is similar to the stator winding	The rotor consists of rotor bars which are permanently shorted with the help of end rings
3	We can easily add rotor resistance by using slip ring and brushes	Since the rotor bars are permanently shorted, it is not possible to add external resistance

4	Due to presence of external resistance high starting torque can be obtained	Starting torque is low and cannot be improved
5	Slip ring and brushes are present	Slip ring and brushes are absent
6	This motor is rarely used only 10 % industry uses slip ring induction motor	Due to its simple construction and low cost. The squirrel cage induction motor is widely used
7	Rotor copper losses are high and hence less efficiency	Less rotor copper losses and hence high efficiency
8	Slip ring induction motor are used where high starting torque is required i.e. in hoists, cranes, elevator etc.	Squirrel cage induction motor is used in lathes, drilling machine, fan, blower printing machines etc.

## Torque Slip Characteristic of an Induction Motor

The Torque Slip Characteristic is represented by a rectangular hyperbola. For the immediate value of the slip, the graph changes from one form to the other. Thus, it passes through the point of maximum torque when  $R_2 = sX_2$ . The maximum torque developed in an induction motor is called the **Pull Out Torque** or the **Breakdown Torque**. This torque is a measure of the short time overloading capability of the motor.

# LNCT GROUP OF COLLEGES

The torque slip characteristic curve is divided roughly into three regions. They are given below.

- Low slip region
- Medium slip region
- High slip region

The torque equation of the induction motor is given below.

$$T = \frac{k s R_2 E_{20}^2}{R_2^2 + (sX_2)^2} \quad \dots\dots (1)$$

## Low Slip Region

At the synchronous speed,  $s = 0$ , therefore, the torque is zero. When the speed is very near to synchronous speed. The slip is very low and  $(sX_2)^2$  is negligible in comparison with  $R_2$ . Therefore,

$$T = \frac{k_1 s}{R_2}$$

If  $R_2$  is constant, the torque becomes

$$T = k_2 s \quad \dots\dots (2)$$

When  $k_2 = k_1/R_2$

From the equation (1) shown above, it is clear that the torque is proportional to slip. Hence, in the normal working region of the motor, the value of the slip is small. The torque slip curve is a straight line.

## Medium Slip Region

As the slip increases, the speed of the motor decreases with the increase in load. The term  $(sX_2)^2$  becomes large. The term  $R_2^2$  may be neglected in comparison with the term  $(sX_2)^2$  and the torque equation becomes as shown below.

$$T = \frac{k_3 R_2}{s X_2^2} \quad \dots (3)$$

At the standstill condition, the torque is inversely proportional to the slip.

## High Slip Region

Beyond the maximum torque point, the value of torque starts decreasing. As a result, the motor slows down and stops. At this stage, the overload protection must immediately disconnect the motor from the supply to prevent damage due to overheating of the motor.

The motor operates for the values of the slip between  $s = 0$  and  $s = s_M$ . Where,  $s_M$  is the value of the slip corresponding to the maximum torque. For a typical induction motor, the pull-out torque is 2 to 3 times the rated full load torque. The starting torque is about 1.5 times the rated full load torque.

The curve shown below shows the **Torque Slip Characteristic** of the Induction Motor.

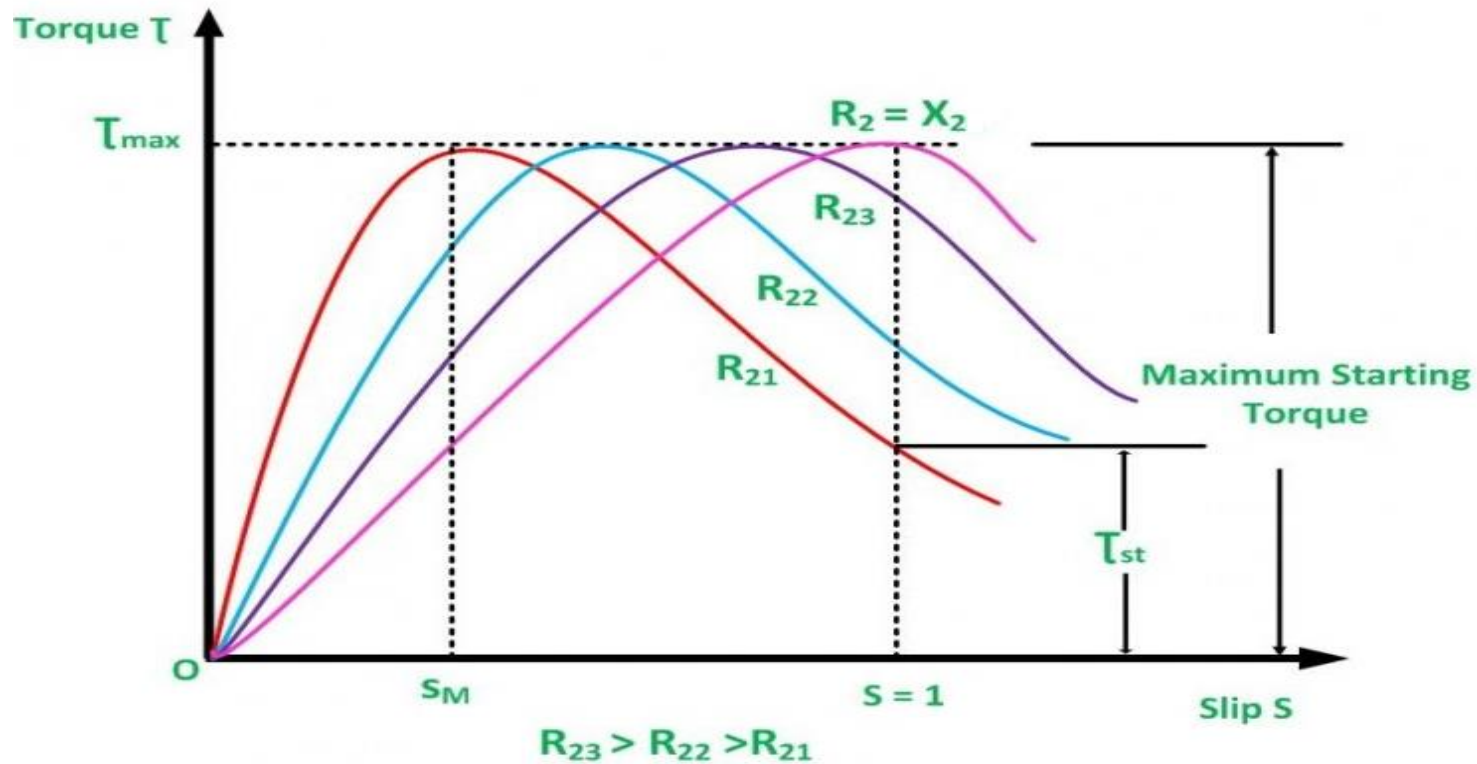

### Torque Speed Characteristic of an Induction Motor

Torque Speed Characteristic is the curve plotted between the torque and the speed of the induction motor.

At the maximum torque, the speed of the rotor is expressed by the equation shown below.

$$N_M = N_S (1 - s_M)$$



The curve below shows the **Torque Speed Characteristic**.

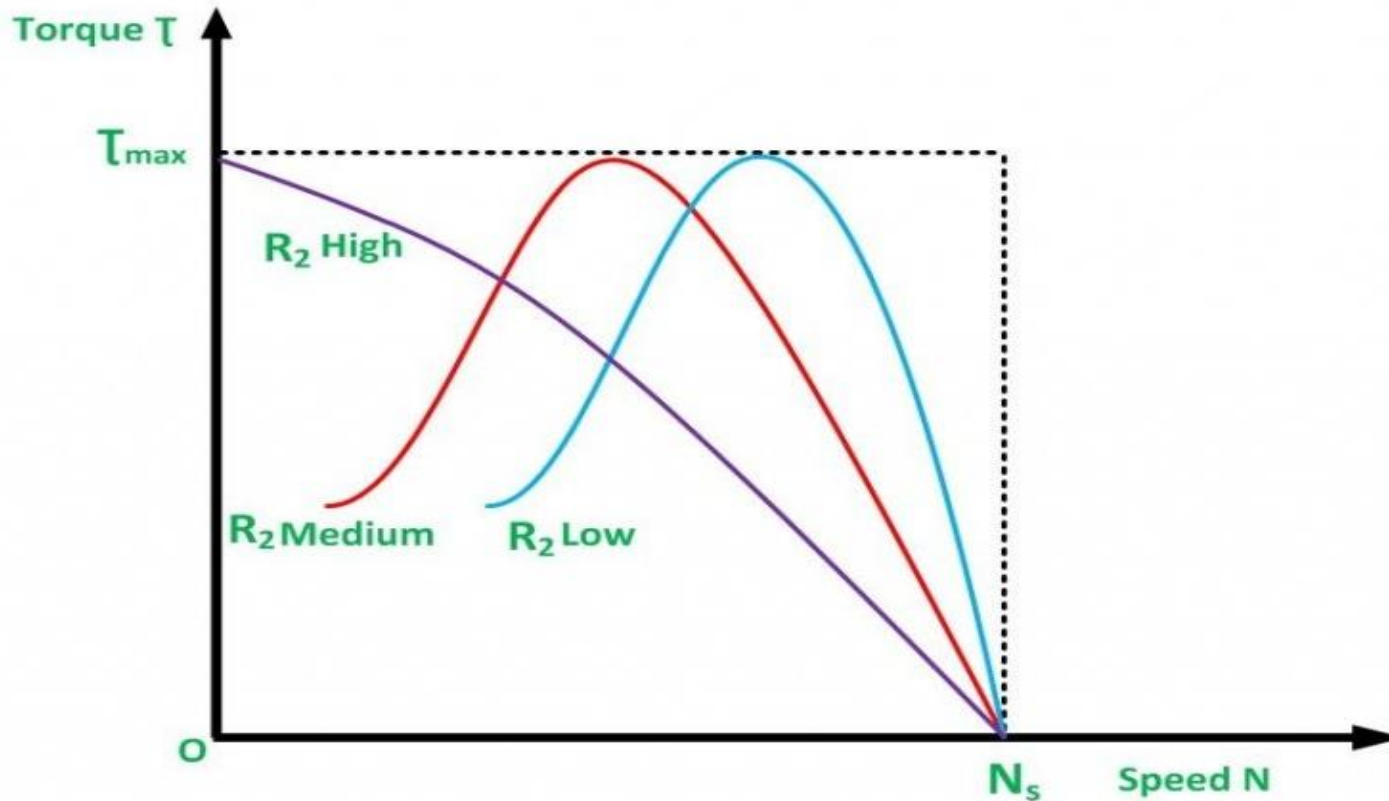

The maximum torque is independent of the rotor resistance. But the exact location of the maximum torque  $\tau_{max}$  is dependent on it. Greater, the value of the  $R_2$ , the greater is the value of the slip at which maximum torque occurs. As the rotor resistance increases, the pull-out speed of the motor decreases. In this condition, the maximum torque remains constant.

# LNCT GROUP OF COLLEGES

## SOLVED PROBLEMS

Q.1. A 3-phase IM is wound for 4 poles and is supplied from a 50 Hz. system. Calculate: (a) synchronous speed, (b) speed of the motor when running at 4% slip.

**Solution:**

$$(a) \text{ Synchronous speed, } N_s = \frac{120 \cdot f}{P} = \frac{120 \times 50}{4} = 1500 \text{ RPM}$$

$$(b) \text{ Speed of the motor } N = (1 - S) N_s,$$

$$N = (1 - 0.04) 1500 = 1440 \text{ RPM}$$

Q.2 A 3-phase induction motor runs at 3000 rpm at no-load and 2500 rpm at full load when supplied with power from a 50 Hz, 3-phase line.

- (a) How many poles does the motor have?
- (b) What is the percentage slip at full load?
- (c) What is the corresponding frequency of rotor voltage?
- (d) What is the corresponding speed of the rotor field with respect to rotor?

**Solution:**

Supply frequency  $f = 50$  Hz.,

Synchronous speed,  $N_s = 3000$  rpm

Full load speed,  $N = 2500$  rpm

$$\therefore \text{(a) Poles of the motor, } P = \frac{120 \cdot f}{N_s} = \frac{120 \times 50}{3000} = 2$$

$$\text{(b) \% slip at full load, } S = \frac{N_s - N}{N_s} \times 100 = \frac{3000 - 2500}{3000} \times 100 = 16.67 \%$$

$$\text{(c) Frequency of rotor voltage } f' = S \cdot f = 0.1667 \times 50 = 8.335 \text{ Hz.}$$

$$\text{(d) Speed of the rotor field w.r.t. rotor} = \frac{120 \times f'}{P} = \frac{120 \times 8.335}{2} = 500 \text{ RPM}$$

## ASSIGNMENT QUESTIONS

- Q.1. Explain the working principle of 3-phase induction motor.
- Q.2. Describe the applications of induction motor.
- Q.3. Describe the constructional features of induction motor.
- Q.4. Draw the torque-slip characteristic of 3-phase induction motor.
- Q.5. A 3-phase IM is wound for 6 poles and is supplied from a 50 Hz. system. Calculate: (a) synchronous speed, (b) speed of the motor when running at 3% slip, (c) frequency of emf induced in rotor

## REFERENCES

1. <https://circuitglobe.com>
2. A textbook of Electrical Technology volume II Basic electrical engineering by B.L. Theraja & A.K. Theraja
3. A textbook of Basic Electrical and Electronics Engineering By Dr. Pankaj swarnakar and Shiv Shankar Mishra, Satya Prakashan, New Delhi
4. <https://electricalacademia.com>
5. <https://www.sciencedirect.com>
6. <https://www.electrical4u.com>
7. <https://electricalacademia.com>
8. <https://www.electriceasy.com>